

INDIANOLA MUNICIPAL UTILITIES

WATER UTILITY

PROCEDURE MANUAL FOR

MATERIALS & CONSTRUCTION STANDARDS

May 23, 2011

**WATER UTILITY
PROCEDURE MANUAL
TABLE OF CONTENTS**

SECTION	SUBSECTION	TITLE	PAGE
1		General	1
2		Plan Submissions and Approval	1
3		Water Mains Specifications	2
	3.1	General Design Characteristics	2
	3.2	Component Materials	3
	3.2.1	Piping	3
	3.2.2	Fittings	4
	3.2.3	Valves	5
	3.2.4	Blow Offs	7
	3.2.5	Special Gaskets	7
	3.2.6	Hydrants	7
	3.2.7	Bolting Material	8
	3.2.8	Polyethylene Wrap	8
	3.2.9	Tracer System	8
	3.2.10	Thrust Blocks	9
	3.3	Excavating and Backfill	9
	3.3.1	Trench Excavating	9
	3.3.2	Trench Backfill	10
	3.4	Design & Installation	10
	3.4.1	Piping	10
	3.4.2	Valves	11
	3.4.3	Hydrants	12
	3.4.4	Boring Encasements	12
	3.4.5	Tracer System	12
	3.5	Leakage Testing	13
	3.6	Disinfection	13

4		Water Service Lines	14
	4.1	General Design Characteristics	14
	4.2	Materials	14
	4.2.1	Tapping Saddles	14
	4.2.2	Service Lines	14
	4.2.3	Corporation Cocks	15
	4.2.4	Curb Stop Valves and Boxes	15
	4.2.5	Water Meter Pits	15
	4.3	Design & Installation	15
	4.3.1	Taps	15
	4.3.2	Service Line	15
	4.3.3	Curb Stop Box	15
	4.3.4	Water Meter	16
	4.3.5	Water Meter Pits	16
5		Backflow Prevention	17
	5.1	General	17
	5.2	Component Materials	18
	5.3	Design & Installation	19
6		Standard Drawings	21
		Thrust Blocks WM-101	
		Trench Bedding SW-104	
		Tracer System MW-102	
		Tracer System Fire Hydrant WM-201	

1. General

- 1.1. The purpose of this Procedural Manual is to, in as much as possible, describe the materials and construction methods allowed by Indianola Municipal Utilities (the “Utility”) for connections to the water distribution system as described in Section 2.3 of the Utility’s Water Utility Service Plan.
- 1.2. All definitions contained in the Water Utility Service Plan shall apply to this Procedural Manual.

2. Plan Submittal Required

- 2.1. Combining sanitary sewer plans with water plans is encouraged.
- 2.2. It is the responsibility of the person or entity, as appropriate, filing plans to identify contaminated or corrosive soil and use the appropriate materials specified.
- 2.3. Drawings shall be complete showing locations of water mains, hydrants, valves and miscellaneous appurtenances for the proposed construction.
- 2.4. All plans must be certified by an Iowa registered, licensed professional civil or sanitary engineer showing water mains to be constructed and appurtenances connected thereto.
- 2.5. Submit the required number of final plans to Indianola Planning and Zoning Department and two (2) sets to the IMU Administrative Office for review. Include product information sheet for joint restraint system to be used.
- 2.6. Application forms required by the Water Supply Section of the Environmental Protection Division of the Department of Natural Resources shall be submitted along with the plans for review and approval. The Water Supply Section of the Environmental Protection Division of the Department of Natural Resources shall not approve plans without approval by the City of Indianola and IMU.
- 2.7. Special Provisions: All material and construction methods to be used which are not in accordance with or in addition to these specifications shall have Special Provisions prepared and certified by the Project Engineer and approval of the Utility.

3. Water Main Specifications

3.1. General Design Characteristics

- 3.1.1. Minimum water main diameter: 8” unless otherwise allowed by the Utility.
- 3.1.2. Location tracer wire must be buried with all water main pipes.
- 3.1.3. Private water mains 4” and larger shall conform to the Utility’s standards.
- 3.1.4. Dead ends shall be minimized by looping whenever possible.
- 3.1.5. Dead ends shall terminate with a hydrant or approved flushing device.
- 3.1.6. Extend water mains to the furthest boundary of the plat, site plan or property or as directed by the Utility.
- 3.1.7. Hydrants
 - 3.1.7.1. In no case will a hydrant be placed on a main that has less than 500 GPM flow rate at 20 psi residual.
 - 3.1.7.2. A hydrant shall be placed at each street intersection and equally spaced between intersections. Maximum hydrant spacing in residential areas shall be 500 linear feet; maximum hydrant spacing in industrial and commercial areas shall be 300 linear feet. A hydrant shall be placed at the end of each cul-de-sac. The spacing of the hydrants may require adjustment to meet fire flow requirements according to City of Indianola’s Fire Code.
 - 3.1.7.3. Each hydrant must be independently valved.
- 3.1.8. Separation of water mains and sewers
 - 3.1.8.1. General
 - 3.1.8.1.1. Maintain horizontal separation of 10’ between water and sewer lines.
 - 3.1.8.1.2. Where conditions prevent 10’ horizontal separation, minimum may be reduced by placing water main in a separate trench or in the same trench on a bench of undisturbed earth providing 1) the bottom of water main is at least 18” above the top of sewer pipe and 2) the minimum horizontal distance shall be no less than 3’.
 - 3.1.8.2. Separation of water mains and sewer force mains
 - 3.1.8.2.1. Maintain horizontal separation of 10’ between water main and sewer force main unless conditions prevent it.
 - 3.1.8.2.2. Where 10’ separation is prevented-
 - 3.1.8.2.2.1. Construct force main of water main materials meeting a minimum pressure rating of 150psi
 - 3.1.8.2.2.2. Maintain a minimum separation of 4 linear feet

3.1.8.3. Separation of water main crossing sewers

- 3.1.8.3.1. The water main shall be installed over the sewer with a minimum vertical separation of 18” from top of sewer to bottom of water main. If conditions exist that prohibit this separation, the water main shall not be placed closer than 6” above or 18” below the sewer main. The water pipe shall be placed so that the ends of the pipe are spaced equidistant from the crossing.
- 3.1.8.3.2. Water and sewer pipes shall be adequately supported and have watertight joints. Backfill material shall be a low permeability soil with 10’ of the point of crossing.

3.1.8.4. Water Crossings

- 3.1.8.4.1. Water mains entering or crossing streams shall be of ductile iron pipe with flexible locking watertight joints or shall be installed in steel casing pipe.
- 3.1.8.4.2. Top of the water main shall be below the natural bottom of the streambed a minimum of 5’. Trench shall be backfilled with crushed rock or gravel.
- 3.1.8.4.3. Water mains shall be securely anchored to prevent movement or pipe.
- 3.1.8.4.4. Easily accessible shut off valves shall be located at each side of the water crossing, outside of the floodway.

3.2. Component Materials

3.2.1. Piping

3.2.1.1. General

3.2.1.1.1. Shipment and storage

- 3.2.1.1.1.1. Small pipe shall not be telescoped inside larger pipe.
- 3.2.1.1.1.2. All pipe materials are to be handled by use of slings, hoist, skids or other approved means.
- 3.2.1.1.1.3. Dropping or rolling of pipe materials is not permitted.
- 3.2.1.1.1.4. Remove pipe contaminated with mud and surface water from the site

3.2.1.1.2. Defective or damaged pipe may be cause for rejection and removal from the site.

3.2.1.2. Ductile iron pipe (D.I.)

- 3.2.1.2.1. ANSI A21.50 manufactured in accordance with ANSI 21.51; minimum thickness, Class 52 according to AWWA C151 for 4” – 24” sizes. Standards for larger sizes as specified by the Utility.
- 3.2.1.2.2. Enameline pipe using standard cement lining; ANSI A21.51 (AWWA C104).
- 3.2.1.2.3. Outside coating
 - 3.2.1.2.3.1. Coat outside of pipe with bituminous enamel.
 - 3.2.1.2.3.2. Asphalt according to AWWA C151

- 3.2.1.2.4. Joint type
 - 3.2.1.2.4.1. Push-on or mechanical in accordance with ANSI A21.15 according to AWWA C111
 - 3.2.1.2.4.2. Restrained, buried: Pipe manufacturer's standard field removable system
 - 3.2.1.2.4.3. Restrained, in structures: Restraining gland, flanged or grooved
 - 3.2.1.2.4.4. Flanged: According to AWWA C111
 - 3.2.1.2.4.5. Grooved: According to AWWA C606
 - 3.2.1.2.4.6. Gaskets: According to AWWA C111
- 3.2.1.2.5. Markings
 - 3.2.1.2.5.1. Name of manufacturer
 - 3.2.1.2.5.2. Size and class
 - 3.2.1.2.5.3. Spigot insertion depth gauge
- 3.2.1.2.6. Pipe with damage to cement mortar lining will be rejected. Field patching will not be permitted except at cut ends.
- 3.2.1.2.7. Use restrained or locked pipe joint on ductile iron pipe at stream crossings.
- 3.2.1.3. PVC (Poly Vinyl Chloride)
 - 3.2.1.3.1. PVC pipe shall conform to AWWA C-900 specifications, Class 150 (DR 18) with cast iron diameters. AWWA C-905 for pipe larger than 12".
 - 3.2.1.3.2. Joint type
 - 3.2.1.3.2.1. Shall be electrometric gasket push-on type joints. Solvent cement joints are strictly prohibited.
 - 3.2.1.3.2.2. Conform to AWWA C-900 or AWWA C905
 - 3.2.1.3.2.3. Restraining system manufactured integrally into pipe
 - 3.2.1.3.2.4. Ductile iron mechanical device designed for joint restraint complying with the requirements of ASTM F 1674
 - 3.2.1.3.3. Markings
 - 3.2.1.3.3.1. Name of manufacturer
 - 3.2.1.3.3.2. Size and class
 - 3.2.1.3.3.3. Spigot insertion depth gauge
 - 3.2.1.3.3.4. National Sanitation Foundation (NSF) seal
- 3.2.2. Fittings
 - 3.2.2.1. Fittings for PVC shall be as specified for ductile iron pipe.
 - 3.2.2.2. Fittings for 3" through 20" size ductile iron pipe and PVC shall be compact iron per ANSI/AWWA C153/A21.53 of gray cast iron or full sized ductile iron per ANSI/AWWA C110/A21.10. The pressure rating for gray cast iron fittings shall be 250 psi.
 - 3.2.2.3. Mechanical joint.
 - 3.2.2.4. Furnished with a cement mortar lining of standard thickness and given a seal coat of bituminous enamel per AWWA C104.
 - 3.2.2.5. Provide restrained or locking joints on downward or vertical bends.
 - 3.2.2.6. Remove fittings contaminated with mud and surface water from the site

3.2.3. Valves

3.2.3.1. General

- 3.2.3.1.1. Open direction is counterclockwise
- 3.2.3.1.2. Rated to test pressure of 250 pounds per square inch.
- 3.2.3.1.3. Type permitting repacking or replacement of 'O' rings, under pressure when wide open.
- 3.2.3.1.4. Provide any non-standard special tools required for disassembling and repacking valves.
- 3.2.3.1.5. Must be coated both inside and out with a protective coating that meets or exceeds AWWA C550.
- 3.2.3.1.6. Each valve shall have the name of the manufacturer and the year when cast on the body with raised letters.
- 3.2.3.1.7. Valves for buried service shall each be provided with an adjustable screw type valve box consisting of a base, a center section, a top section, and a cover. Provide slide-type valve box when installing in pavement. The cover shall be plainly marked on top "Water".
- 3.2.3.1.8. Bolts and hex nuts used on bonnet of the valve shall be the manufacturer's standard, either fabricated from "cor-ten", stainless steel, or other alloy steel for corrosion resistance or electroplated with zinc or cadmium. The hot-dip process, in accordance with ASTM Standard Designation A-153, is not acceptable for the threaded portions of the bolts and nuts.
- 3.2.3.1.9. Joints
 - 3.2.3.1.9.1. For buried installations, use mechanical joints per AWWA C111. Comply with the Bolting Material specifications for joint nuts and bolts
 - 3.2.3.1.9.2. For installation within structures, flanged with dimensions and drillings according to AWWA C110 or ANSI B16.1 class 125.

3.2.3.2. Gate Valves

- 3.2.3.2.1. Standard requirement for valves less than or equal to 12".
- 3.2.3.2.2. Resilient wedge and conform to AWWA C509 (gray iron or ductile iron) or AWWA C515 (ductile iron) and NSF 61.
- 3.2.3.2.3. Non-rising stem with 2" square operating nut; open counter clockwise.
- 3.2.3.2.4. O-ring seals
 - 3.2.3.2.4.1. 200 psi working pressure.
 - 3.2.3.2.4.2. Double O-rings permanently lubricated between seals.
 - 3.2.3.2.4.3. Lubricant certified for use in potable water.
- 3.2.3.2.5. Epoxy coated.
- 3.2.3.2.6. External bolts and hex nuts shall be stainless steel according to ASTM A 240, Type 304.

3.2.3.3. Butterfly Valves

- 3.2.3.3.1. Standard requirement for valves larger than 12"
- 3.2.3.3.2. Conform to AWWA C504, Class 150B and NSF 61.
- 3.2.3.3.3. Equipped with Ni-resist discs.
- 3.2.3.3.4. O-ring seals and stainless steel shaft will be required.
- 3.2.3.3.5. Valves and operators shall be for buried service.
- 3.2.3.3.6. Equipped with a 2" square operating nut and lifetime grease pack; open counter clockwise.

3.2.3.4. Tapping Valves

- 3.2.3.4.1. Gate valve complying with AWWA C509 or AWWA C515

3.2.3.4.2. Sleeve

- 3.2.3.4.2.1. Minimum 14 gauge.
- 3.2.3.4.2.2. Stainless steel according to ASTM A 240, Type 304.
- 3.2.3.4.2.3. Working pressure 150 psi.
- 3.2.3.4.2.4. Must fully surround pipe.
- 3.2.3.4.2.5. Flanged with dimensions and drillings according to AWWA C110 or ANSI B16.1 class 125.

3.2.3.4.3. Minimum Sleeve Length:

Outlet Flange Size	Minimum Sleeve Length
4"	15"
6"	15"
8"	20"
10"	25"
12"	25"
Over 12"	As approved by the Utility

3.2.3.4.4. Gasket

- 3.2.3.4.4.1. Completely surround pipe.
- 3.2.3.4.4.2. Minimum thickness 0.125"
- 3.2.3.4.4.3. Nitrile rubber.

3.2.3.4.5. Outlet Flange to be stainless steel complying with ASTM A 240, Type 304; ANSI B16.1, 125 pound pattern.

3.2.3.4.6. Hex Nuts & Bolts to be stainless steel complying with ASTM A 240, Type 304.

3.2.3.4.7. Use tapping valve assemblies only where specified or required by the Utility.

3.2.3.5. Valve Boxes

- 3.2.3.5.1. Cast iron screw type adjustable with cast iron stay-put covers marked with "WATER". Provide slide-type when installing in pavement. Inside diameter of valve box is to be a minimum of 5 1/8".

3.2.4. Blow Offs

- 3.2.4.1. Assembly of minimum 1 1/2" curb stop, stop box and riser as required.
- 3.2.4.2. Provide as necessary to raise 2 inch operating nut to within 3 feet of the finished grade.
- 3.2.4.3. Stem diameter according to valve manufacturer's recommendations, but not less than 1 inch.

3.2.5. Special gaskets for contaminated soils (as reported to the Utility)

- 3.2.5.1. For soils contaminated with gasoline or volatile organic compounds, use fluoroelastomer (Viton) gaskets.
- 3.2.5.2. For other soil contaminants, special gaskets will be required as determined by the Utility upon consultation with appropriate engineering professionals.

3.2.6. Hydrants

- 3.2.6.1. Test rated to 300 pounds per square inch.
- 3.2.6.2. Shall conform to AWWA C502, break-flange hydrant; breakaway items include stem coupling and flange.
- 3.2.6.3. Shall be Mueller Centurion Model A-423, Clow Medallion Model 2524-4B, or Watrous Pacer Model WB-67. The Watrous Pacer WB-67 must have the following options; double top operating nut (top nut ductile iron, bottom nut bronze) with weather shield and oil reservoir.
- 3.2.6.4. Coat interior and exterior of hydrant, except exterior above grade mark, with two coats of asphalt varnish per AWWA C502; paint exterior of hydrant above grade mark with one coat of primer and finish paint of highway yellow.
- 3.2.6.5. Provide two (2) 2 1/2" hose nozzles on one (1) 4 1/2" pumper nozzle, o-ring packing.
- 3.2.6.6. Nozzles shall be threaded or pinned into barrel. No leaded connections will be allowed.
- 3.2.6.7. Nozzle threads: National Standard.
- 3.2.6.8. Provide 6" mechanical joint inlet and 5 1/4" main valve unless otherwise directed.
- 3.2.6.9. Cap and operating nut shall be Type C. Open counter clockwise.
- 3.2.6.10. Breakaway flange shall be 4" above grade.
- 3.2.6.11. Auxiliary Valve: Use gate valve and valve box as specified for gate valves. Auxiliary valves are required for all hydrants.
- 3.2.6.12. External bolts and hex nuts shall be stainless steel according to ASTM A 193, Grade B 8.
- 3.2.6.13. Gate valve, pipe and fittings as specified by the Utility in this Procedure Manual.

- 3.2.7. Bolting Material: This section shall apply unless otherwise specified.
- 3.2.7.1. All bolts and hex nuts used for mechanical and flanged joints shall be fabricated from a high strength “Cor-Ten”, “Usalloy” or other approved high-strength, low-alloy steel that is corrosion resistant as manufactured according to AWWA C111. Stainless steel is strongly preferred.
 - 3.2.7.2. Provide ceramic-filled, baked-on, fluorocarbon resin coating for bolts and nuts.
 - 3.2.7.3. Include factory-applied lubricant that produces low coefficient of friction for ease of installation.
- 3.2.8. Polyethylene Wrap
- 3.2.8.1. Comply with AWWA C105.
 - 3.2.8.2. Tubes or sheets shall have minimum thickness of 8 mil.
 - 3.2.8.3. Use when placing main in contaminated or corrosive soils.
 - 3.2.8.4. May be required under special circumstances determined applicable by the Utility.
- 3.2.9. Tracer System
- 3.2.9.1. A tracer wire will be installed with all new mains including both PVC and Ductile Iron mains. Refer to Standard Drawings MW-102 and, as appropriate, WM-201.
 - 3.2.9.2. All tracer wire shall be solid, single, insulated, direct-bury wire, AWG #12, type UF.
 - 3.2.9.2.1. Linear low-density polyethylene (LLDPE) insulation suitable for direct burial applications.
 - 3.2.9.2.2. Minimum insulation thickness of 0.045 inches.
 - 3.2.9.2.3. Underground wire splices and wires terminated below ground level shall be protected against deterioration and/or corrosion using Scotch cast splicing kits as manufactured by 3M Company, or approved equal.
 - 3.2.9.3. Ground rod 3/8” diameter, 60 inch steel rod uniformly coated with metallically bonded electrolytic copper. Install adjacent to connections to existing piping and at other locations determined by the Utility.
 - 3.2.9.4. Ground rod clamp made of high-strength, corrosion-resistant copper alloy.
 - 3.2.9.5. Splice kit made of inline resin with split bolt for 1kV and 5kV. Shall insulate and seal single conductor and unshielded cable splices for direct bury and submersible applications.
 - 3.2.9.6. Tracer wire station at locations determined by the Utility in Section 3.4.5 of these procedures.

3.2.10. Thrust Blocks

- 3.2.10.1. Provide concrete thrust blocks where piping changes direction, dead-ends, and at hydrants.
- 3.2.10.2. Use Iowa DOT Class C concrete rated to 4,000 psi
- 3.2.10.3. Carry thrust blocks to undisturbed edge of trench for bearing.
- 3.2.10.4. Minimum thickness of thrust blocks: 18”.
- 3.2.10.5. Bearing area of thrust blocks, Square Feet:

Pipe Size	90° Bend	45° Bend	11 ¼, 22 ½ Bend	Tee, Dead End
4	3	1	2	1
6	6	3	2	4
8	11	6	3	8
10	17	9	5	12
12	6	13	7	17
14	33	18	9	23
16	43	23	12	31

- 3.2.10.6. Refer to Standard Drawing WM-101 for general arrangement of thrust blocks. Place plywood between fittings and thrust block. No bolts shall come into contact with the concrete thrust block. A sheet of plastic shall be wrapped around the pipe including the bolt circle before the concrete is placed.

3.3. Excavating and Backfill

3.3.1. Trench Excavating

- 3.3.1.1. Keep trench width as narrow as possible and still provide adequate room for backfill and jointing. See Standard Drawing SW-104.
- 3.3.1.2. Maximum width of trench at top of the pipe shall be the outside diameter of pipe plus 12 inches each side of pipe.
- 3.3.1.3. Maintain vertical walls of excavation below the top of the pipe.
- 3.3.1.4. Provide sheeting, shoring and bracing where required to hold walls of excavation, to protect existing structures and utilities and provide safety for workers, and in accordance with OSHA standards.
- 3.3.1.5. Bottom of Trench
 - 3.3.1.5.1. Hand shape to provide uniform bearing and support for full length of pipe barrel against undisturbed earth.
 - 3.3.1.5.2. Provide suitable bell hole at each pipe joint after bottom of the trench has been graded.
 - 3.3.1.5.3. Remove large clods, stones, and other foreign material from bottom of trench.
 - 3.3.1.5.4. When unstable material is encountered which may not provide a suitable foundation for pipe, remove the unsuitable material and replace with stabilizing material. Place pipe bedding on top of stabilizing material.

- 3.3.1.5.5. If trench bottom is extremely hard or is in rock or rubble where there is possibility of pipe being subject to point contact, over excavate trench bottom 6" minimum below grade and backfill with pipe bedding material.
- 3.3.1.5.6. Bedding Material
 - 3.3.1.5.6.1. Normal bedding for water main in dry trench conditions shall consist of natural soil found in the trench bottom. The contractor may elect to use sand or gravel.
 - 3.3.1.5.6.2. In wet trench conditions, crushed stone or gravel not exceeding 1" diameter shall be used as normal bedding.
 - 3.3.1.5.6.3. When in the opinion of the inspector, the trench bottom is such that 1" stone or gravel cannot provide a proper foundation for the pipe, the aggregate used shall be either crushed limestone or crushed gravel with a maximum size no greater than 2".
- 3.3.2. Trench Backfill
 - 3.3.2.1. Backfill trench immediately after the location of connections and appurtenances have been made.
 - 3.3.2.2. Use no large stones, large clods, organic matter, rubbish, frozen or unsuitable material in backfill.
 - 3.3.2.3. Carefully hand tamp selected material to 1' above top of pipe. Backfill remaining trench with excavated material to minimum 90% Standard Proctor density in accordance with ASTM D698.
 - 3.3.2.4. Street crossings: Provide full depth of crushed rock bedding to the bottom of the pavement. Hand-tamp select material to 1' above top of pipe. Compact remaining trench to minimum 95% Standard Proctor density in accordance with ASTM D698.

3.4. Design & Installation

3.4.1. Water Main Piping

- 3.4.1.1. Lay pipe on a dry trench with 5'6" earth cover except where otherwise directed by the Utility. Install water main and appurtenances in accordance with AWWA C-600 (ductile iron) or AWWA C-605 (PVC) as applicable. Locate water main 3' back of curb line of proposed pavement.
- 3.4.1.2. Clean pipe interior of foreign material before lowering into trench. Keep clean at all times by securely closing open ends of pipe and fittings. Use minimum amount of gasket lubricant, applying to gasket only. Do not apply to inside of bell. No pipe shall be laid in water, nor shall water be allowed to rise in the trench around the pipe.
- 3.4.1.3. Place in trench in sound, undamaged condition. Do not injure pipe coating or lining. Use web sings to install or move pipe. Use of end hooks or dropping of pipe is prohibited. No blocking of the pipe shall be allowed. Uniform bearing along the full length of the pipe barrel shall be maintained at all times.

- 3.4.1.4. Cut pipe in neat and in a workman like manner without damage to pipe. Smooth and bevel cut ends of push-on type pipe to prevent gasket damage. Completely coat damaged ends of cut ductile iron pipe with bituminous sealer. Do not install pipe fittings showing blisters or holes.
 - 3.4.1.5. Before installing, tap pipe lightly with light hammer to detect cracks. Defective, damaged or unsound pipe shall be removed from the job site.
 - 3.4.1.6. Deflect pipe joints as required in accordance with recommendations of pipe manufacturers, except pipe deflection shall not exceed three (3) degrees for ductile iron pipe and one and one-half (1 ½) degrees for PVC pipe. If deflection exceeds the maximum allowable, use suitable fittings with ductile iron retainer glands or thrust block to secure fittings. Use ductile iron retainer glands, all thread and/or thrust blocks as directed by the Utility.
 - 3.4.1.7. Cover ends of pipe with watertight plug or cap when pipe laying is not in progress.
 - 3.4.1.8. Plug or cap all pipe ends or fittings left for future connections; construct concrete thrust blocks as shown on Standards Drawings for dead ends (alternate method). Do not block end of pipe with concrete.
 - 3.4.1.9. Provide concrete thrust blocks at all fittings, at dead ends and at alternate pipe joints where pipe joints are deflected to accommodate small changes in pipe directions.
 - 3.4.1.10. Provide restrained or locked joints on fittings and pipe joints adjacent to downward, vertical bends; thrust blocks may be required; contact the Utility for further specifications.
- 3.4.2. Valves
- 3.4.2.1. When water main is installed in proposed street right-of-way, install valves at street intersection as shown on Standard Drawings. Isolate pipe servicing each block.
 - 3.4.2.2. When water main is installed in other locations, install valves to isolate no more than 800 linear feet of water main in residential areas and 400 linear feet in industrial or commercial areas.
 - 3.4.2.3. Install valve with stems vertical and centered in valve box. Carefully compact backfill around valve box to required grade. Valves larger than 12" shall be butterfly valves.
 - 3.4.2.4. Where construction terminates, the main will be valved 20' before the terminating point. At the terminating point, a plug, blow off valve, and thrust block shall be installed.
 - 3.4.2.5. Operate to ensure proper working condition and that operator can be placed on valve nut.

3.4.3. Hydrants

- 3.4.3.1. Install hydrants using tee (of anchoring tee), holding pipe or anchoring coupling and other appurtenances as required.
- 3.4.3.2. Hydrant drains shall not be connected to or located within 10' of sanitary sewer and storm drains.
- 3.4.3.3. Install plumb at 5' bury depth. Set at elevation required for flange to be 4" above finish grade lines.
- 3.4.3.4. Set on concrete foundations. Provide one cubic yard of pea gravel or washed rock backfill at each hydrant.
- 3.4.3.5. Tighten all valves and nuts and operate hydrant to assure all parts are in working condition.
- 3.4.3.6. Hydrants shall be blocked. Carefully compact backfill around hydrant to required grade.
- 3.4.3.7. Touch up paint as necessary to cover paint damaged during installation.

3.4.4. Boring Encasements

- 3.4.4.1. Required where IDOT has roadway jurisdiction.
- 3.4.4.2. Casing pipe shall be a minimum 6" in diameter greater than the water main that is being installed.
- 3.4.4.3. Casing pipe thickness shall be determined by the conditions of the area or as required by IDOT.
- 3.4.4.4. All joints in the casing pipe shall be welded in an acceptable manner.
- 3.4.4.5. Each 20' section of water main shall be fitted with a minimum of two (2) supports per section throughout the casing.
- 3.4.4.6. Seal end of casing pipe with manufactured end seals.
- 3.4.4.7. Ductile iron water main shall be used when casing pipe is required.

3.4.5. Tracer System & Stations

- 3.4.5.1. Tracer wire shall be installed with pipe. Refer to Standard Drawings WM-102 and, as appropriate, WM-201.
- 3.4.5.2. Wire shall be laid along the bottom of the pipe beginning with the first laid section and end at the connection to an existing main. The ends of the wire are to be protected using the material specified in Section 3.2.9.
- 3.4.5.3. Wire shall run continuously along the pipe and be attached to the bottom of the pipe at the midpoint of each pipe length, using two inch wide, ten mil thickness, polyethylene pressure sensitive tape.
- 3.4.5.4. No below grade splicing of the wire shall be permitted except as authorized by the Utility.
- 3.4.5.5. Tracer wire shall be exposed at each water main valve and hydrant.
 - 3.4.5.5.1. Hydrant: extend wire from the pipe connecting to the hydrant tee along the hydrant branch, and up to the ground surface where it shall be secured to a tracer terminal box.
 - 3.4.5.5.2. Main valve: extend wire from the exterior main valve box and secure to a tracer terminal box.

3.5. Leakage Testing

- 3.5.1. Required test(s) performed at contractor's expense.
- 3.5.2. AWWA C600 (ductile iron) and AWWA 605 (PVC) standards to be followed, as applicable to the type of main being tested
- 3.5.3. Flush out main before test to remove air. Insert taps to release trapped air.
- 3.5.4. Test pressure shall be 150 psi unless otherwise specified.
- 3.5.5. Water pumped during test to maintain pressure shall be pumped from a tank or drum so quantities pumped can be accurately measured.
- 3.5.6. Maximum allowable leakage is less than two (2) pounds per square inch (psi) the first hour or less than five (5) pounds per square inch (psi) the second hour.
- 3.5.7. Examine trench for leakage during test. Replace all defective pipe and fittings that do not pass leakage test. Repeat test until requirements have been met and approved by the inspector.
- 3.5.8. After testing is completed, remove corporation cocks if not used for water service connections and install brass plugs.

3.6. Disinfection

- 3.6.1. Disinfect and sample prior to placing main in service and in accordance with AWWA 651.
- 3.6.2. Two consecutive sets of acceptable samples, taken at least 24 hours apart, shall be collected from the new main.
- 3.6.3. At least one set of samples shall be collected from every 1,200 ft. of the new water main plus one set from the end of the line and at least one set from each branch.
- 3.6.4. All samples shall be tested for bacteriological (chemical and physical) quality in accordance with standard methods for the examination of water and wastewater.
- 3.6.5. Disinfect by injecting a solution of calcium hypochlorite and water at slow rate to provide a minimum content of 50 ppm on water main; allow system to stand full of solution for 24 hours. Do not use chlorine tablets without the approval of the Utility.
- 3.6.6. Minimum free chlorine residual at pipe extremities; 10mg/l at end or test period. If requirement is not met, repeat disinfection procedure.
- 3.6.7. Operate all valves and hydrants in new main to assure full disinfection. Repeat test procedure if necessary.
- 3.6.8. Thoroughly flush main after test until extremities indicate same chlorine residual as supply water.
- 3.6.9. If test fails, the contractor shall pay for water used for additional testing and flushing.
- 3.6.10. After completion of disinfection, the Utility will collect bacteriological samples from new mains and the samples will be sent, by the contractor, to a certified, independent laboratory for testing. Samples must test "SAFE". If samples test "UNSATISFACTORY" or "UNSAFE", repeat disinfection procedures until sample tests "SAFE". Contractor will pay for all testing costs.

4. Service Line Specifications

4.1. General Design Characteristics

- 4.1.1. Shall comply with local plumbing and fire codes in addition to the Utility's specifications contained in this Procedural Manual
- 4.1.2. All service lines will be required to have a corporation cock, a curb stop valve, a curb stop box, an unrestrictive ball valve before the meter and an unrestrictive ball valve after the meter.
- 4.1.3. Tapping saddles will be required at all times.
- 4.1.4. Existing taps and service lines may be used if they meet current standards. If a tap or service line does not meet current standards it must be shut off at the corporation cock and disconnected from the water main. Abandoned water service lines must be shut off at the corporation cock and disconnected from the water main.
- 4.1.5. When it is not economically feasible, as determined by the Utility, to place the required water meter inside the building it will be serving, a water meter pit can be installed in accordance with Section 4.2.5 of these specifications.

4.2. Materials

4.2.1. Tapping Saddles

- 4.2.1.1. All services shall have saddles that are nylon coated with a double stainless steel strap.

4.2.2. Service Lines

- 4.2.2.1. Minimum size of a service line is three-fourths (3/4) inch.
- 4.2.2.2. Service lines three-fourths (3/4) inch through two (2) inches
- 4.2.2.3. Type K (heavy) soft annealed and seamless copper that complies with ASTM B 88
- 4.2.2.4. Iron, plastic or lead service lines are strictly prohibited
- 4.2.2.5. Approved copper pipe with brass fittings from the water main to the water meter.
- 4.2.2.6. PVC pipe only allowed under roadways or as specifically authorized by the Utility. PVC shall meet standards of ASTM D 1785, SDR 21, Schedule 80, Type S joints.
- 4.2.2.7. Brass pipe and Polyethylene pipe not allowed unless specifically authorized by the Utility. When duly authorized, brass pipe shall be red, seamless, according to ASTM B 43; polyethylene pipe shall be Class 200 according to AWWA C901 and subject to tracer wire requirements in Section 3.4.5.
- 4.2.2.8. Service lines larger than two (2) inches shall be ductile iron. The ductile iron will be cement-mortar lined, ANSI A21.50, class 52 mechanical or push joint pipe. C-900 PVC pipe will also be allowed and shall be installed to water main specifications using push joint pipe.

4.2.3. Corporation Cocks

- 4.2.3.1. All three-fourths (3/4) inch through two (2) inch corporation cocks shall be made of brass and conform to AWWA C800 standard.
- 4.2.3.2. They shall be suitable for tapping PVC or iron pipe as applicable and use of flared copper pipe.
- 4.2.3.3. All taps larger than two inches will be made with an approved tapping tee and valve.

4.2.4. Curb Stop Valves and Boxes

- 4.2.4.1. Curb stop valves shall be made of brass and conform to AWWA C800 standard.
- 4.2.4.2. They shall be a ninety (90) degree turn valve for flared copper service pipe.
- 4.2.4.3. A gate valve shall be used instead of curb box for service lines larger than two inches.
- 4.2.4.4. Curb stop boxes shall be metal with a sliding extension, arch pattern base, stationary rod and lid.

- 4.2.5. Water Meter Pits: All water meter pits shall be Mueller/McCullough pits. Mueller/McCullough thermal coil meter box with insulating pad and locking lid may be used for five-eighths (5/8) inch to two (2) inch meters, or approved equal.

4.3. Design & Installation

4.3.1. Taps

- 4.3.1.1. All taps must be made using an approved tapping saddle.
- 4.3.1.2. All three-fourths (3/4) and one (1) inch taps will be made on the upper half of the water main at a forty-five (45) degree angle. Taps one and one-half (1 1/2) inch and larger can be made at a ninety (90) degree angle.
- 4.3.1.3. A four (4) inch main will not receive a tap larger than three-fourths (3/4) inch.
- 4.3.1.4. No multiple taps.

- 4.3.2. Service Line: All service lines will have at least five feet of ground cover to protect it from freezing.

4.3.3. Curb Stop Box

- 4.3.3.1. The curb stop will be located at least six (6) feet but not more than eight (8) feet from the property line, in the public right-of-way unless otherwise directed by IMU's water department.
- 4.3.3.2. The curb stop shall be marked with a wooden or steel post painted blue. The post shall extend at least three (3) feet above the ground. This post can be removed and the curb stop box brought to ground level at the time of final inspection.

4.3.4. Water Meter

4.3.4.1. All meters shall have a radio read attachment.

4.3.4.2. All meters shall have an unrestrictive ball valve before the meter and an unrestrictive ball valve after the meter with the following spacing face to face of valves:

5/8" meter	11-3/4"
3/4" meter	13-3/4"
1" meter	15-3/4"
1-1/2" meter	13-1/4"
2" meter	17-1/4"

4.3.4.3. The water meter shall be located so it will be accessible for meter readers and meter repair personnel. All meters shall be placed not more than six (6) feet from a floor drain.

4.3.4.4. All meters shall be installed in a horizontal position.

4.3.4.5. Water meters shall be installed by utility personnel.

4.3.4.6. Clearance Around Meter: Five-eighths (5/8) to one (1) inch meters must have an unobstructed accessibility of twenty-four (24) inches on one side (front only) and at least eight (8) inches of clearance on all other sides. Meters larger than one (1) inch must have an unobstructed accessibility of thirty-six (36) inches on one side (front only) and at least twelve (12) inches on all other sides.

4.3.5. Water Meter Pits

4.3.5.1. All water meter pits are to be placed on private property.

4.3.5.2. The pit shall have a minimum depth of five (5) feet below grade.

4.3.5.3. The water meter will be installed so the meter is at least twelve (12) inches off the bottom of the meter pit.

5. Backflow Prevention

5.1. General

5.1.1. Hazard Definitions

5.1.1.1. Reduced Pressure Principal backflow preventer (RPP)

5.1.1.1.1. Generally used in high hazards or as otherwise required by the Utility. High hazards are those determined by the Utility to cause an impairment of the quality of potable water by creating an actual hazard to the public health through poisoning or through the spread of disease by sewage, industrial fluids, or waste.

5.1.1.1.2. A properly designed air gap at the water service entrance may be substituted for a RPP as specifically allowed by the Utility and only as installation as containment devices.

5.1.1.2. Double Check Valve Assembly (DCVA)

5.1.1.2.1. Generally used in low hazards or as otherwise required by the Utility. Low hazards are those determined by the Utility to cause an impairment of the quality of potable water to a degree which does not create a hazard to the public health, but which does adversely and unreasonably affect the aesthetic qualities of potable waters for domestic use.

5.1.1.2.2. Consists of two independently acting, internally loaded check valves, four properly located test cocks, and two isolation valves.

5.1.1.3. Other types of backflow prevention devices may be required by the Utility for isolation purposes.

5.1.2. RPP device specifically required for the following types of facilities and conditions:

5.1.2.1. Breweries, distilleries, bottling plants (health/containment hazard)

5.1.2.2. Car washes

5.1.2.3. Chemical plants

5.1.2.4. Dairies (health/containment hazard)

5.1.2.5. Dentist office

5.1.2.6. Die works

5.1.2.7. Fertilizer plants

5.1.2.8. Film laboratories or processing plants

5.1.2.9. Fire protection systems (subject to other sections of these Procedures)

5.1.2.10. Food and beverage plants (health/containment hazard)

5.1.2.11. Hospitals, clinics, and medical offices

5.1.2.12. All irrigation systems (supersedes UPC provisions)

5.1.2.13. Laboratories

5.1.2.14. Laundries and dry cleaning plants

5.1.2.15. Machine tool plants (health/containment hazard)

5.1.2.16. Metal processing plants (health/containment hazard)

5.1.2.17. Morgues and mortuaries

5.1.2.18. Nursing homes

- 5.1.2.19. Packing houses and rendering plants
- 5.1.2.20. Paper products plants
- 5.1.2.21. Pesticide manufacturing or handling facilities (exterminators)
- 5.1.2.22. Petroleum processing plants
- 5.1.2.23. Petroleum storage yard (health/containment hazard)
- 5.1.2.24. Pharmaceutical or cosmetic plant
- 5.1.2.25. Piers, docks or waterfront facilities
- 5.1.2.26. Power plants
- 5.1.2.27. Radioactive materials plants
- 5.1.2.28. Restaurants with soap ejectors and/or industrial type disposal
- 5.1.2.29. Rubber plants
- 5.1.2.30. Sand and gravel plants
- 5.1.2.31. Schools
- 5.1.2.32. Swimming pools
- 5.1.2.33. Sewage treatment plants
- 5.1.2.34. Tall buildings (over 3 stories or with booster pump)
- 5.1.2.35. Veterinary establishments
- 5.1.2.36. Premises having an auxiliary water system not connected to the public water system
- 5.1.2.37. Premises having a water storage tank, reservoir, pond, or similar source
- 5.1.2.38. Premises heated by steam or hot water, or cooling systems where chemical water conditions are or may be used
- 5.1.2.39. Premises having submerged inlets to equipment
- 5.1.2.40. Premises having self-draining yard hydrants, fountains, hose boxes, or similar devices
- 5.1.2.41. Others specified by the Utility

5.2. Component Materials

5.2.1. Assemblies for containment

- 5.2.1.1. Meets requirements of ANSI-AWWA Standard C510-89 or C511-89
- 5.2.1.2. Listed by the International Association of Plumbing and Mechanical officials.

5.2.2. Assemblies for containment in a fire protection system

- 5.2.2.1. Meets requirements of Factory Mutual Research Corporation (FM), Underwriters Laboratory (UL), section 5.2.1. and other applicable city building and fire codes.
- 5.2.2.2. Devices smaller than 2 ½" not listed by UL and tested by FM may be allowed upon approval by the Utility.

5.3. Design & Installation

5.3.1. Design

5.3.1.1. Assemblies for containment – water services

- 5.3.1.1.1. Air gap or approved reduced pressure principle backflow prevention assembly for water services having one or more cross connections which the Utility classifies as a high hazard.
- 5.3.1.1.2. Approved double check valve assembly for water services having no high hazard cross connections but having one or more cross connection which the Utility classifies as a low hazard.

5.3.1.2. Assemblies for containment – fire protection systems

- 5.3.1.2.1. Submit plans, including backflow prevention devices, to the Indianola Fire Chief in addition to other applicable authorities.
- 5.3.1.2.2. Reduced pressure principle backflow prevention assembly on new and existing fire protection systems determined to have any of the following:
 - 5.3.1.2.2.1. Direct connections from public water mains with an auxiliary water supply on or available to the premise for a pumper connection.
 - 5.3.1.2.2.2. Interconnections with auxiliary supplies such as reservoirs, rivers, ponds, wells, mills, or other industrial water systems.
 - 5.3.1.2.2.3. Use of antifreezes or other additives in the fire protection system.
 - 5.3.1.2.2.4. Combined industrial or domestic with high hazard and fire protection systems supplied from the public water mains only, with or without gravity storage or pump suction tanks.
 - 5.3.1.2.2.5. Any other facility, connection, or conditions which may cause contamination.
- 5.3.1.2.3. Double check valve assembly required for all other fire protection systems on new systems at the time of installation and on existing systems at the time they are upgraded.

5.3.2. Installation

- 5.3.2.1. The required assemblies for containment shall be installed in the horizontal plumbing immediately following the meter or as close to that location as deemed practical by the Utility. It shall be located upstream from any branch piping. This installation method does not eliminate the responsibility of the customer to protect the Utility's water distribution system from contamination or pollution between the backflow prevention assembly and the water main.
- 5.3.2.2. Reduced pressure principal backflow assemblies shall not be installed so as to be protected from flooding; nor in underground vaults or pits.
- 5.3.2.3. Thermal expansion shall be provided for when installing an assembly for containment where hot water is used within the water system.
- 5.3.2.4. Provisions shall be made to convey the discharge of water from reduced pressure principle backflow assemblies to a suitable drain.
- 5.3.2.5. No assemblies shall be installed in a place where it would create a safety hazard, such as, but not limited to, over an electrical panel or above ceiling level.
- 5.3.2.6. A second assembly, sized to handle temporary water flow needed during testing or repairs, may be installed in parallel piping.
- 5.3.2.7. All assemblies shall be installed so they are accessible for testing.
- 5.3.2.8. Shut-off valves shall be installed and meet the appropriate requirements contained in these Procedures.

6. Standard Drawings

The following Standard Drawings are hereby incorporated by reference. The Utility may update these drawings as appropriate. Updates by parties issuing Standard Drawings must be approved by the Utility prior to being incorporated by reference.

SUDAS	WM-101	Thrust Blocks (2 drawings)
SUDAS	SW-104	Pressure Pipe Trench Bedding
SUDAS	WM-102	Tracer System
SUDAS	WM-201	Tracer System – Fire Hydrant Assembly

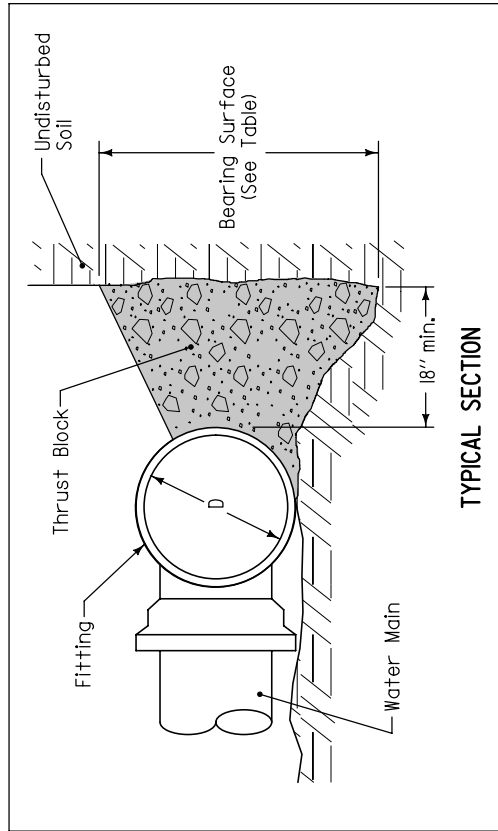

Extend thrust blocks to undisturbed soil. Excavation into trench wall may be necessary.

Form vertical surfaces of poured concrete thrust blocks except on bearing surface.

Encase all fittings in polyethylene wrap. Do not allow concrete to directly contact joints or fitting bolts.

Diameter of Pipe, D (inches)	MINIMUM BEARING SURFACE (sf)				
	Bends		Tees and Dead Ends		90°
	1 1/4°	22 1/2°	45°	90°	
4	1	1	2	4	3
6	1	2	4	8	6
8	2	4	7	14	10
10	3	6	11	21	15
12	4	8	16	29	21
14	5	11	21	39	28
16	7	14	27	50	36
18	9	17	34	63	45
20	11	21	42	78	55
24	15	31	60	111	78
30	24	47	92	171	120
36	34	67	132	244	173

Minimum surface area based on water pressure of 150 psi and allowable soil pressure of 1,000 psf.

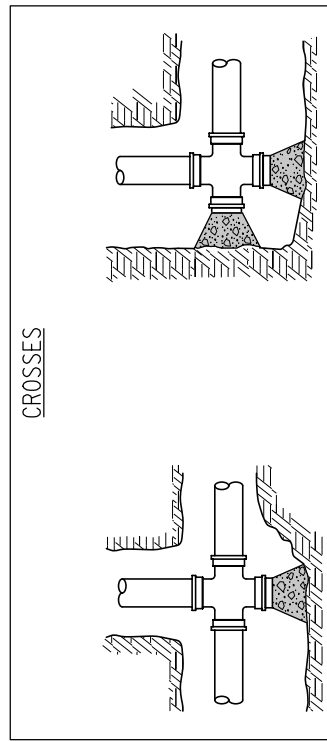
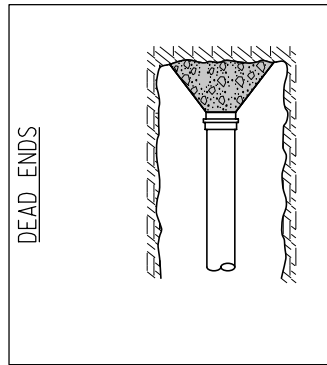
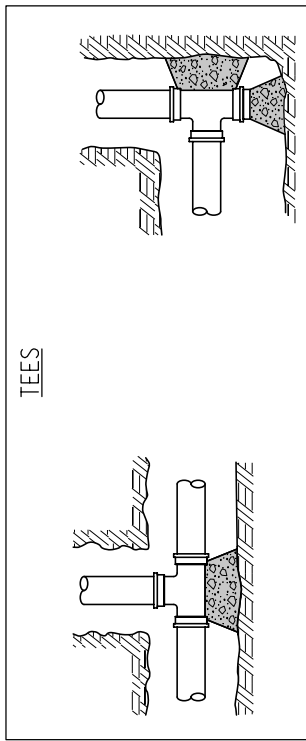
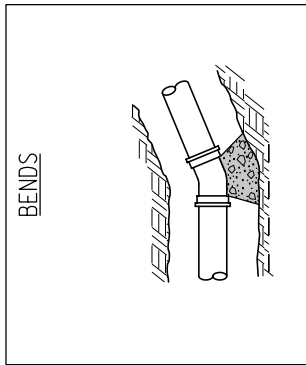

TYPICAL PLAN

		REVISION NEW 04-21-09
		WM-101 STANDARD ROAD PLAN SHEET 1 of 2
REVISIONS: New. Replaces SUDAS Figure 5010.1		
SUDAS DIRECTOR: <i>Deane M. Smith</i>		DESIGN METHODS ENGINEER

THRUST BLOCKS

CHANGES IN PIPE DEPTH

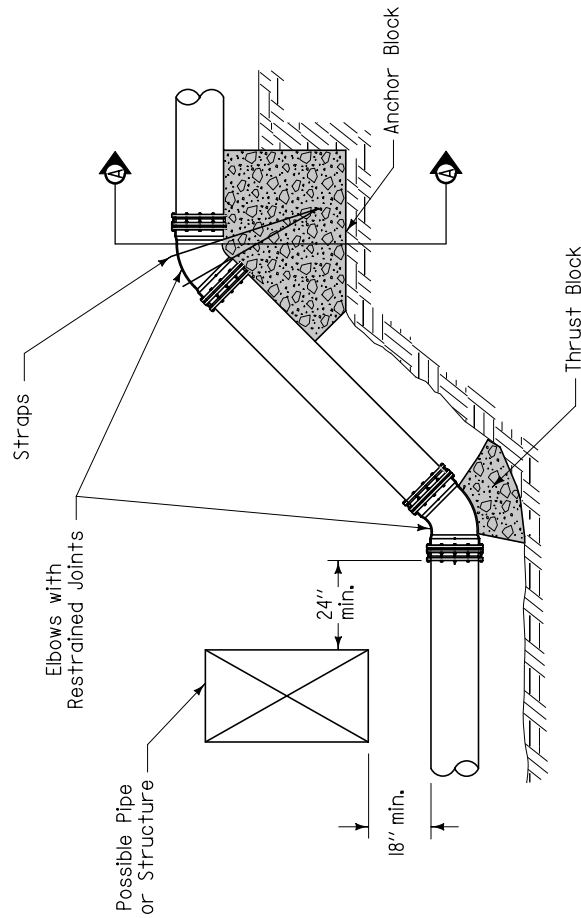

ELEVATION

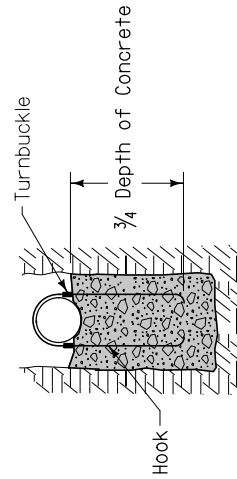

SECTION A-A

DEAD ENDS (ALTERNATE METHOD)

Use only when allowed by the Engineer, or when specified in the contract documents.

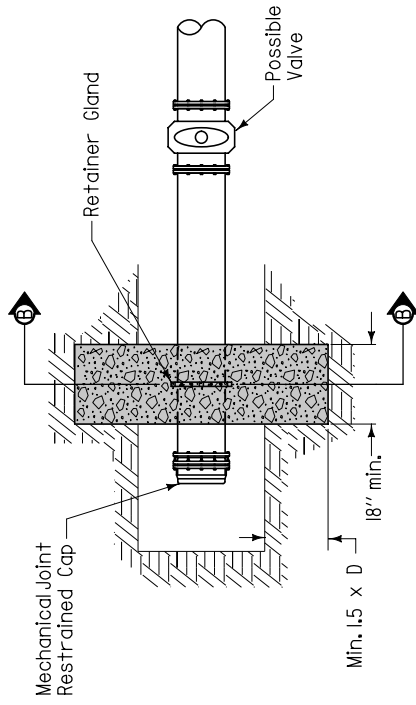

PLAN

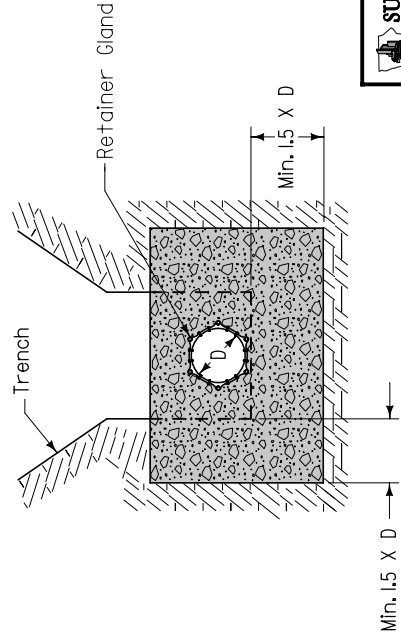

SECTION B-B

		REVISION NEW 04-21-09
		WM-101 STANDARD ROAD PLAN REVISIONS: New. Replaces SUDAS Figure 5010.1.
SUDAS DIRECTOR <i>Deane M. Kelly</i> DESIGN METHODS ENGINEER		SHEET 2 of 2

THRUST BLOCKS

BEDDING CLASSES

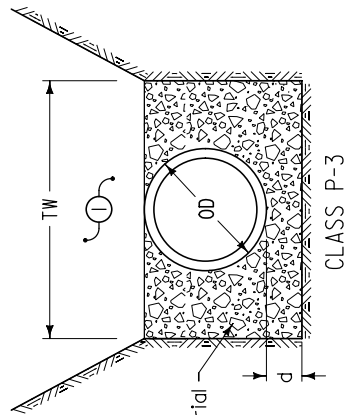
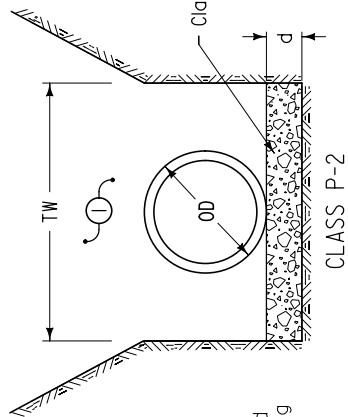
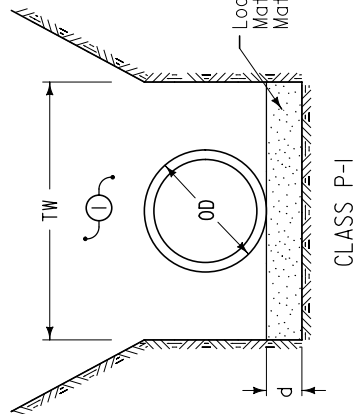

ALLOWABLE BURY DEPTH

DUCTILE IRON, AWWA C151, CLASS 52

Pipe Diameter (Inches)	Class P-1 Bedding	Class P-2 Bedding	Class P-3 Bedding
4	40'	40'	40'
6	40'	40'	40'
8	40'	40'	40'
10	36'	40'	40'
12	31'	40'	40'
14	26'	40'	40'
16	23'	37'	40'
18	20'	34'	40'
20	18'	32'	40'
24	16'	29'	38'
30	13'	23'	31'
36	13'	22'	30'
42	13'	21'	29'
48	13'	19'	27'
54	13'	19'	27'

PVC, AWWA C900 & C905, DR18

Pipe Diameter (Inches)	Class P-1 Bedding	Class P-2 Bedding	Class P-3 Bedding
4	19'	23'	40'
6	19'	23'	40'
8	19'	23'	40'
10	19'	23'	40'
12	19'	23'	40'
14	19'	23'	40'
16	19'	23'	40'
18	19'	23'	40'
20	19'	23'	40'
24	19'	23'	40'

① Place remainder of bedding and backfill material as specified in the contract documents.

Key

- OD = Outside diameter of pipe
- TW = Trench width at top of pipe;
Min. = OD+18 inches OR 1.25xOD+12 inches
(whichever is greater)
- d = Depth of bedding material below pipe;
Min. = OD/8 OR 4 inches
(whichever is greater)

		REVISION
		NEW 04-21-09
FIGURE 3010.104		SW-104
STANDARD ROAD PLAN		SHEET 1 of 1
REVISIONS: New.		
[Signature]		Deane M. [Signature]
[Signature]		DESIGN METHODS ENGINEER
PRESSURE PIPE TRENCH BEDDING		

- ① Extend tracer wire up fire hydrant barrel to internal terminals of tracer wire station and back down. Refer to WM-201 for details of fire hydrant assembly.
- ② Clamp tracer wire to ground rod at system termination points.

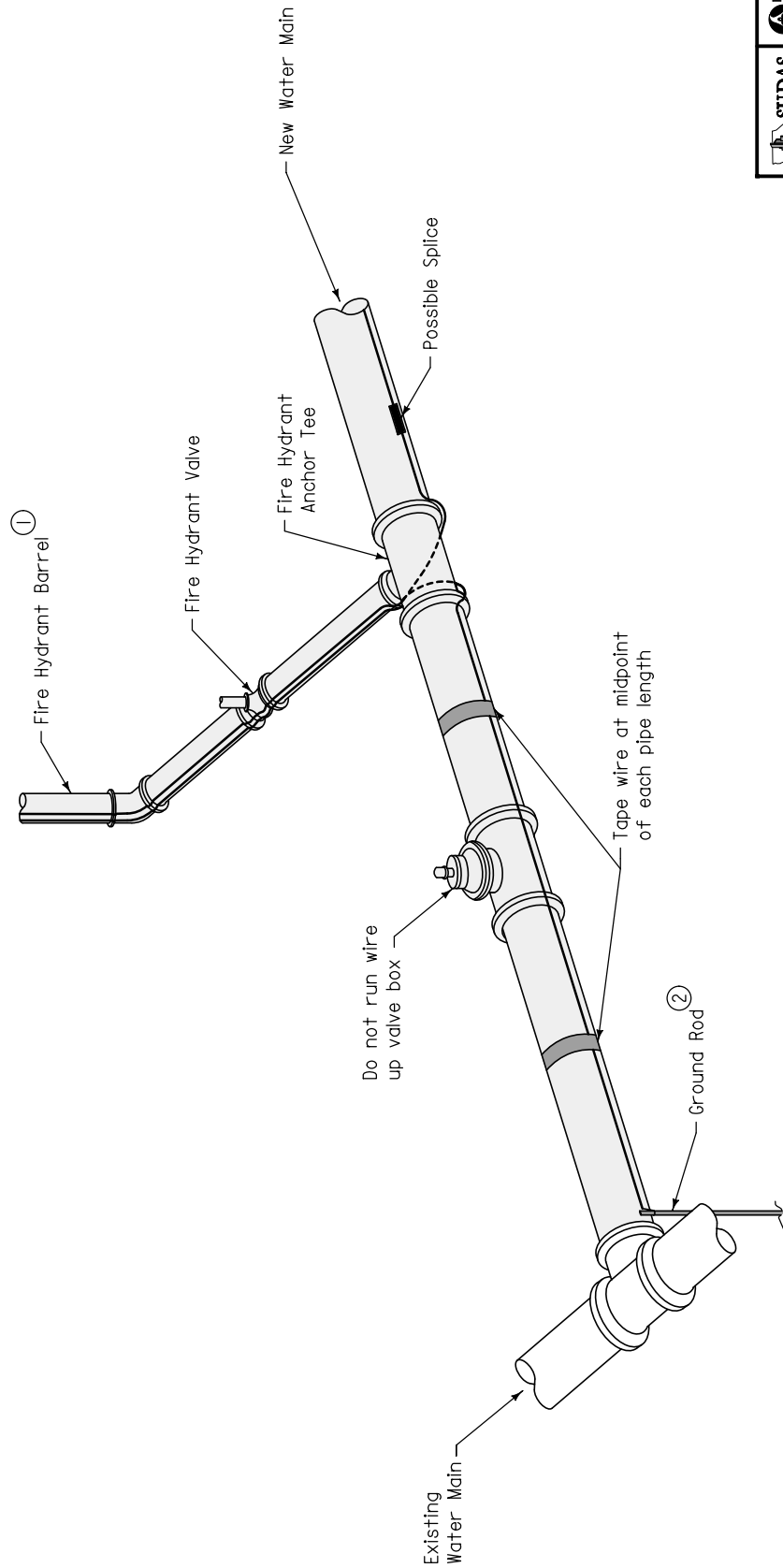

TYPICAL INSTALLATION

SUDAS	Iowa Department of Transportation	REVISION	NEW	04-21-09
		FIGURE 5010.102	STANDARD ROAD PLAN	
REVISIONS: New. Replaces SUDAS Figure 5010.3		WM-102		
SUDAS DIRECTOR		DESIGN METHODS ENGINEER		
D. Deane		D. Deane		
TRACER SYSTEM				

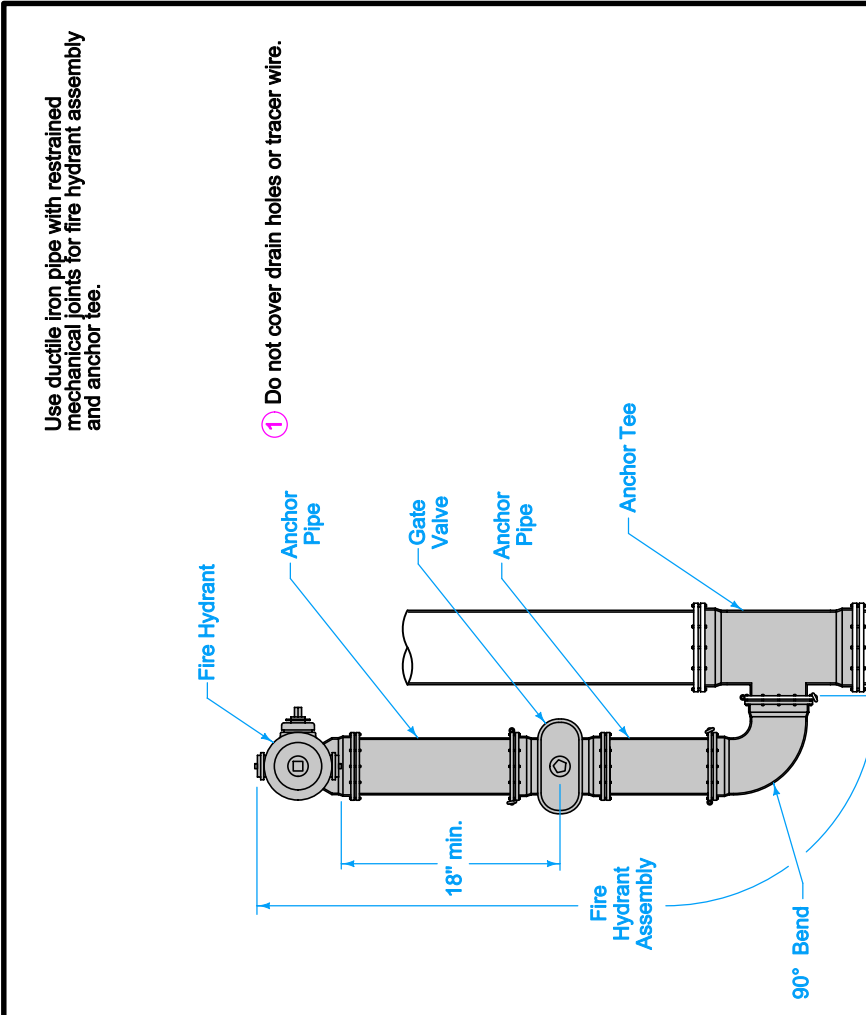
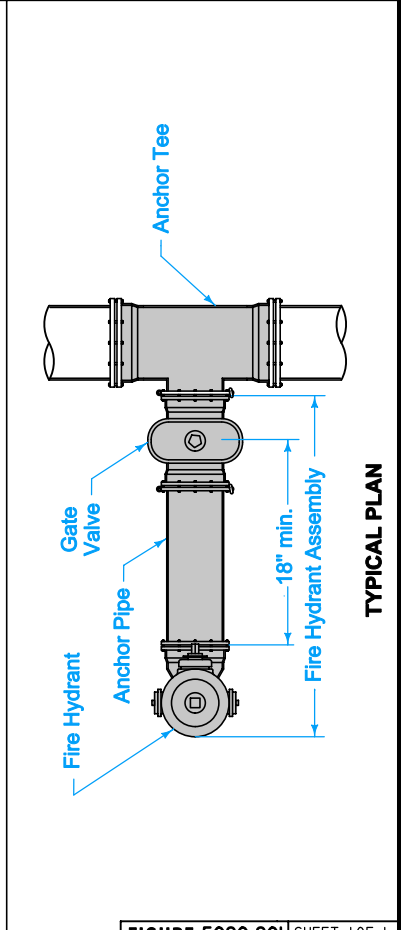
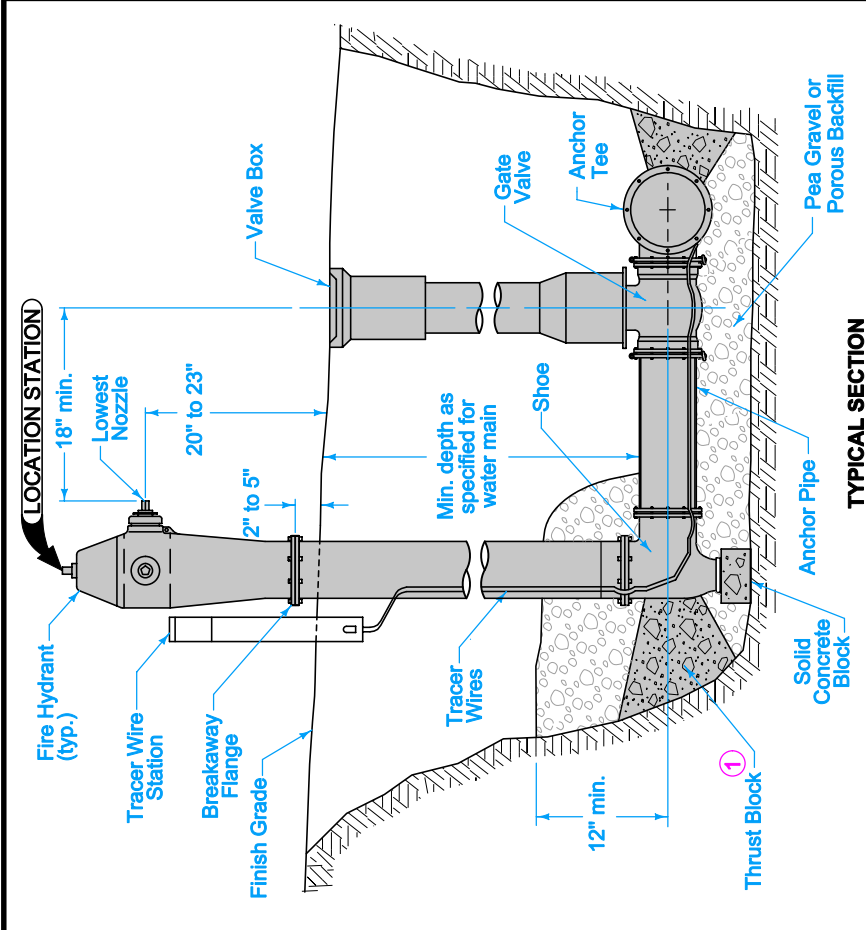

Use ductile iron pipe with restrained mechanical joints for fire hydrant assembly and anchor tee.

① Do not cover drain holes or tracer wire.

	IOWA Department of Transportation 	REVISION 1 04-19-11 WM-201 SHEET 1 of 1
	FIGURE 5020.201 STANDARD ROAD PLAN	REVISIONS: Deleted Note 1 and references, renumbered Note 2, and deleted "typ" after "Tracer Wire Station". <i>Paul D. Wigand</i> SUDAS DIRECTOR <i>Deanne McNeil</i> DESIGN METHODS ENGINEER
		FIRE HYDRANT ASSEMBLY

FIGURE 5020.201 SHEET 1 OF 1